

ACADEMIC PROGRAMS

PURPOSE STATEMENT

The purpose of the Frank J. Rooney School of Adult and Continuing Education is to provide adult students with undergraduate, graduate, and non-credit programs which recognize educational needs of the adult learner and promote lifelong learning. These degree and certificate programs are designed for adult men and women who, because of family and work responsibilities, need a flexible class schedule. The School seeks to attract a diverse student body and to show a caring attitude toward each student regardless of individual backgrounds. The same quality educational programs upon which Barry University's reputation is founded are made available for these students on the Miami and other schools locations in Florida. Recognizing the breadth of experiences of adults, course offerings afford opportunities for further exploration of truth within the Judeo-Christian and Dominican traditions.

Students must meet the same graduation requirements as other Barry University students. However, they may choose from a number of learning options which allow for greater flexibility in program planning and scheduling. Courses are taught by faculty who possess both academic and professional expertise which is complemented by their understanding of adult learners.

Adult students often have attained knowledge outside of the classroom that is appropriate for academic credit. The School of Adult and Continuing Education grants such credit toward an undergraduate degree if students can demonstrate college-level learning. Each student works with an academic advisor who assists the student in preparing for the assessment of experiential learning.

The transcription of portfolio credits by the University Registrar is in accordance with University policies and procedures and with the criteria outlined in the Southern Association of Colleges and Universities(SACS) accreditation handbook. In brief, portfolio credits are designated as experiential learning credits and can be used as general electives and/or to meet certain additional requirements in a specialization or major. **Portfolio credits cannot be used to fulfill Distribution Requirements.**

In accordance with the Mission Statement of the University, students are encouraged to continue to participate in community service and to assume leadership roles and to effect social change.

DISTRIBUTION REQUIREMENTS

At least 45 credits of distributed coursework, including nine credits in each of the following five curricular divisions, must be completed:

Theology and Philosophy.....9 credits
3 credits in Philosophy (any core course in Philosophy)
3 credits in Theology (any core course in Theology)
3 credits in Philosophy or Theology

Written and Oral Communications.....9 credits
3 credits in Oral Communication
Examples: Oral Interpretation, Theories of Communication, Oral Communication
3 credits in Written Communications
Example: English Composition and Syntax (mandatory)
3 credits in Written or Oral Communication

Science and Mathematics.....9 credits
3 credits in Science
Examples: Biology, Environment, Geology
3 credits in Mathematics
Examples: Any Mathematics, at or above the level of College Algebra, except Developmental Courses (based upon placement test results)
3 credits in Mathematics or Science

Social and Behavioral Sciences.....9 credits
3 credits in Social Sciences
Examples: Designated courses in History, Political Science, Geography, Economics
3 credits in Behavioral Sciences
Examples: Designated courses in Anthropology, Psychology, Sociology, Criminal Justice,
3 credits in Social or Behavioral Sciences

Humanities and Arts.....9 credits
3 credits in Humanities
Examples: Designated courses in Language, Literature, or Humanities course
3 credits in Arts
Examples: Designated courses in Art or Music History, Theater History, Creative Dramatics, Photography
3 credits in Humanities or Arts

DEGREE PROGRAMS

The following programs are offered to adult students through the School of Adult and Continuing Education:

BACHELOR OF PUBLIC ADMINISTRATION (B.P.A.)

BACHELOR OF SCIENCE IN HEALTH SERVICE ADMINISTRATION (B.S.)

BACHELOR OF SCIENCE IN INFORMATION TECHNOLOGY (B.S.)

BACHELOR OF SCIENCE IN LEGAL STUDIES (B.S.)

BACHELOR OF SCIENCE IN PROFESSIONAL ADMINISTRATION (B.S.)

BACHELOR OF LIBERAL STUDIES (B.L.S.)

BACHELOR OF PROFESSIONAL STUDIES (B.P.S.)

MASTER OF SCIENCE IN INFORMATION TECHNOLOGY (M.S.)

MASTER OF ARTS IN ADMINISTRATIVE STUDIES (M.A.)

MASTER OF ARTS IN LIBERAL STUDIES (M.A.)

The distribution requirements are intended to achieve a range of learning outcomes in general studies. They are designed to fulfill the following instructional objectives:

1. To explore diverse modes of religious experience and expression with emphasis on Judeo-Christian tradition.
2. To inquire into classic philosophic concepts in order to gain perspective into human issues, judgment and understanding.
3. To demonstrate correct and effective writing.
4. To demonstrate competence in organizational patterns, outlining, and research.
5. To develop clear and persuasive oral expression.
6. To develop an understanding of scientific concepts with emphasis upon scientific observation, scientific methods, and analytical thinking.
7. To develop understanding of mathematical concepts and competence in quantitative skills.
8. To develop the ability to analyze historical, political, or economic data with emphasis upon interrelatedness of events and processes.
9. To examine and understand theoretical and applied aspects underlying individual and group behavior.
10. To develop an appreciation and understanding of a genre or period of literature, or to develop skill in a foreign language.
11. To develop an appreciation of the fine arts (art, music, theatre) from either a historical or creative viewpoint.

REQUIREMENTS FOR THE BACCALAUREATE PROGRAMS

While Barry University provides academic advising, the responsibility for planning individual programs rests with the students. Students are expected to become familiar with the requirements of the University, the School of Adult and Continuing Education, and of their major disciplines.

The following are the requirements for degree completion: Satisfactory completion of a minimum of 120 credits with an average of 2.00 (C). Of the total, a minimum of 48 credits must be in courses numbered above 299. The last 30 credits and the majority of the coursework in the major must be completed at Barry University. Grades of at least "C" must be earned in coursework for the major, prerequisites, and the specialization. All students who are seeking a degree through the School must complete ENG 329, English Composition and Syntax, during the first or second semester of enrollment. In order to satisfactorily complete this course, a grade of C or above must be earned. If a grade below C is earned, the course must be repeated within the next two semesters, and the student must achieve a grade of C or above. Students will not be allowed to continue their academic program until ENG 329 has been successfully completed. Students who do not successfully complete the course after two attempts will be suspended.

Students may be exempt from the requirement by demonstrating proficiency on an English examination administered by the School.

All new students who wish to test out of ENG 329 must sit for the test-out exam in their first semester of enrollment. However, the written communication requirements must be fulfilled.

The computer proficiency requirement must be met. See Academic Information Section.

PORTFOLIO OPTION AND/OR REQUIREMENT CRITERIA FOR B.S., BPA, BLS OR BPS DEGREES

Students must meet all of the following criteria at the time of portfolio submission:

1. Students have been fully accepted (see criteria for full acceptance in this bulletin/catalog).
2. Students must have completed English 329 with a grade of at least C or have demonstrated proficiency on the English exam.
3. Students must be in good academic standing (cumulative grade point average of 2.0 in all Barry University coursework).
4. Students are able to document at least five years of full-time professional work experience and/or community service.

If students do not meet the above criteria, the portfolio may not be submitted.

DEGREE PROGRAMS

BACHELOR OF PUBLIC ADMINISTRATION

The Bachelor of Public Administration (BPA) is the most acceptable undergraduate degree for professional employment in general public administration and is highly desirable for most of the special applications such as police, fire and planning. For those not going on to graduate school but who wish a professional career with government, the BPA is undoubtedly the degree of choice.

This degree meets the standards and guidelines for the Bachelor of Public Administration degree as provided by the Public Administration accrediting organization, the National Association of Schools of Public Affairs and Administration (NASPAA).

The public administration degree is of special interest to the working professional in public and not for profit organizations or those who wish to pursue a career in public management. The course work is designed to provide the student with an understanding and working application of the principles essential to the effective management of all public agencies.

DISTRIBUTION REQUIREMENTS.....45 credits

PORTFOLIO OPTION.....up to 30 credits

ELECTIVES.Variable

REQUIRED COURSES.....18 credits

Students should plan their programs with advisor assistance so that courses can be completed in the sequence which follows.

- POS 303 Public Policy and Administration
- PUB 402 Values and Ethics in Public Administration
- PUB 403 Public Budgeting and Finance
- PUB 404 Concepts and Issues in Public Planning
- PUB 406 Human Resources in the Public Sector
- PUB 410 Methods and Techniques for Public Administration

ELECTIVE PUB COURSES.....6 credits

- These can be taken in any sequence or combination.
- PUB 405 Administrative Law and Process
 - PUB 407 Productivity Improvements in the Public Sector
 - PUB 408 Public Administration and the Political Process
 - PUB 409 Contemporary Issues in Public Safety
 - ADM 301 Labor Relations
 - ADM 303 Administrative Theory and Practice
 - ADM 353 Leadership Development
 - ADM 361 Negotiation: Theory and Practice
 - ADM 412 Quality and Productivity
 - ADM 464 Strategic Human Resources Administration
 - POS 302 Comparative State and Local Government

ADDITIONAL REQUIREMENTS.....21 credits

Twenty-one additional credit hours shall be earned in public administration, emergency medical training, management, business, political science, criminal justice, fire science or classes approved by the program director in health service administration, social work, or sociology or portfolio credits attributable to any of the disciplines included in this paragraph. These twenty-one hours may be transferred from a regionally accredited institution, or from discipline-specific portfolio credits and may be lower-level credits.



THE BACHELOR OF SCIENCE IN HEALTH SERVICES ADMINISTRATION

The Bachelor of Science in Health Services Administration is designed to prepare the student for a career in the health services industry in an administrative capacity. The program of study will give students a broad view of today's health care system and will prepare its graduates for entry and middle management positions in such areas as hospital, medical or dental clinics, group medical practices, managed care organizations, long-term care facilities, insurance companies, home health agencies, and governmental health agencies. Management skills and business practices used in today's complex health care systems are emphasized.

The objectives of the BS in Health Services Administration are:

- to provide students with a comprehensive foundation in administrative theory and practice pertinent to the health care arena
- to meet the needs of adult students by developing the administrative knowledge, skills, and abilities that are associated with success in the health care organization's workplace
- to meet the needs of health service employers by preparing adult learners to meet the challenges of changing organizations
- to validate lifelong learning through experiential portfolio credit
- to provide a foundation for advanced training and studies beyond the undergraduate level and to instill a desire for lifelong learning
- to deliver the program in a flexible, accelerated format while maintaining academic integrity

Students having health care experience should begin study with either **HSA 319 Health Care Finance**, **HSA 339 Health Law**, or **HSA 410 Management in Health Care**. This experience requirement consists of at least five years of experience, preferably with at least one year in a supervisory or management capacity. Otherwise, students should begin with **HSA 301 The Health Care System**, which is required prior to the six required courses in Health Care Administration. Students who wish to enroll in HSA courses without the experience requirement or the HSA 301 prerequisite may take the 400 level course work only with permission of the academic coordinator. In addition, **HSA 499, Capstone in Health Service Administration** is designed to be the final, course in the Health Service Administration program.

DISTRIBUTION REQUIREMENTS*.....45 credits

*PHI 305 Problems in Philosophy is a required course which is part of the 45 credit distribution requirement.

REQUIRED PORTFOLIO.....up to 30 credits

ELECTIVES.....Variable

REQUIRED COURSES.....18 credits

Students should plan their programs with advisor assistance so that courses can be completed in the sequence which follows.

HSA 319	Health Care Finance
HSA 339	Health Law
HSA 410	Management in Health Care
HSA 425	Public and Community Health
HSA 475	Issues to Health Care
HSA 499	Capstone in Health Services Administration

ADDITIONAL REQUIREMENTS.....12 credits

These can be taken in any sequence or combination. Twelve hours must be taken from the following courses (other courses with the approval of the HSA academic coordinator):

HSA 301	The Health Care System
HSA 441	Health Care for the Elderly
HSA 459	Independent Study in Health Care
ADM	Any ADM prefix course
PSY 329	Understanding and Coping with Stress
PSY 382	Developmental Psychology
PSY 410	Group Dynamics and Decision-Making
PSY 417	Psychology of Aging
PSY 423	Industrial Psychology
PUB 404	Concepts and Issues in Public Planning
PUB 406	Human Resources in the Public Sector
PUB 409	Contemporary Issues in Public Safety

Note: Up to 6 credits of related courses may also be accepted through discipline-specific portfolio credits and/or transfer credits to satisfy additional requirements.

HEALTH SERVICES ADMINISTRATION CERTIFICATE

Students who are in other academic programs who wish to obtain a Health Services Administration Certificate must successfully complete a total of 18 credits from the Health Services Administration core requirements. Please notify your advisor of your intentions.

BACHELOR OF SCIENCE IN LEGAL STUDIES

The Bachelor of Science with a major in Legal Studies degree and Legal Studies Certificate Programs are designed to provide a broad background in fundamental legal studies to students who desire to become paralegals or legal assistants working under the supervision of a lawyer. Legal assistants assume paralegal responsibilities as skilled members of a legal team in law firms, financial institutions, insurance companies, governmental agencies and related entities. In addition, the training and exposure to law and law-related topics in the Legal Studies programs provide students with an appropriate academic foundation if they decide to attend law school. Degree seeking students must submit a portfolio documenting at least 5 years of experiential learning.

The objectives of the BS degree with a major in Legal Studies are:

- to provide students with a comprehensive knowledge of legal systems in state and federal environments
- to meet the needs of adult learners by developing the legal research and writing skills that are essential to success in a legal environment
- to provide adult learners with the critical thinking and communication skills necessary to comprehend and function as a legal assistant within the civil and criminal practice areas of a modern law firm
- to provide a means for adult learners to identify and evaluate experiential learning to assess the impact of prior learning in the workplace or related activities relative to the skills and knowledge that are required to function as a legal assistant/paralegal
- to provide a basis for advanced training and education beyond the baccalaureate level
- to deliver the program in a format that allows for flexibility in program planning and scheduling

Students with no experience in the legal community should begin study with **PLA 301 Law and the Legal System**. Degree-seeking students and certificate program students are awarded a Certificate of Participation upon application after completing a 24-credit core legal studies requirement. Sixty Credit Hour Certificates of Completion are also awarded upon application to degree-seeking and undergraduate certificate program students (see page for a more detailed description). Legal studies certificate students may convert to degree-seeking status any time during the course of their studies. Graduates of the Legal Studies degree and 60 credit hour or post-baccalaureate certificate programs are eligible to sit for the Certified Legal Assistant (CLA) examination that is administered by the National Association of Legal Assistants, Inc. ("NALA"). Undergraduate Certificate programs are open to all Barry University students who choose to complete the applicable Legal Studies ("PLA") courses and elective requirements; a student merely needs to submit an executed certificate application form after review by the student's academic advisor.

Students who are seeking a Bachelor of Science degree with a Legal Studies major or a Bachelor of Liberal Studies degree with a Legal Studies specialization must take the Certified Legal Assistant (CLA) examination, administered by the National Association of Legal Assistants, Inc., (NALA), prior to submitting an application for graduation. Proof of sitting for the CLA examination must be attached to the Application for graduation. The CLA examination is offered at least twice each calendar year in Florida. Information on the CLA examination, eligibility and testing dates and sites can be obtained from NALA at <http://www.nala.org> or by writing to NALA, 1516 South Boston, Suite 200, Tulsa, Oklahoma 74119.

DISTRIBUTION REQUIREMENTS*.....45 credits

PHI 305 Problems in Philosophy is a required philosophy course which is part of the 45 credit distribution requirements.

REQUIRED PORTFOLIO.....up to 30 credits

ELECTIVES Variable

REQUIRED COURSES.....15 credits

Students should plan their programs with advisor assistance so that courses can be completed in the sequence which follows.

PLA 301	Law and the Legal System
PLA 310	Legal Research
PLA 315	Legal Writing
PLA 320	Civil Litigation
PLA 430	Criminal Law Practice

ADDITIONAL REQUIREMENTS.....15 credits

These can be taken in any sequence or combination.

PLA 300	Special Topics
PLA 330	Alternative Dispute Resolution
PLA 339	Health Law
PLA 343	Business Organizations
PLA 350	Real Estate Law
PLA 405	Administrative Law and Process
PLA 440	Contracts
PLA 452	Environmental Law
PLA 460	Probate Proceedings
PLA 470	Immigration Law
PLA 480	Bankruptcy
PLA 483	Family Law

Note: Up to 6 credits of related courses may also be accepted in transfer and/or through discipline-specific portfolio credits, (special topics: Legal Studies) with academic coordinator's approval to satisfy additional requirements.

BACHELOR OF SCIENCE IN INFORMATION TECHNOLOGY

The Bachelor of Science in Information Technology is a current program designed to provide adult students with the theoretical knowledge and technical skills required by today's information technology professionals.

The program is designed for working adults who desire the skills necessary for the proper utilization of information technology in a variety of workplace settings. The curriculum will improve a technologist's depth of knowledge and skills in analysis, design, implementation, and use of both information technology core skills and specialization skills (if specialization is selected).

Course sequencing is designed to gradually improve a student's technical, critical thinking, and leadership skills. Students will examine positions of responsibility and expertise in various technical areas, will explore the skills necessary for lifelong learning—the requisite for success in this ever-evolving field, and will be exposed to solid foundation necessary for further study in the field of Information Technology. In doing so, students will:

- become familiar with current technologies and tools while learning new techniques that will lead to the development of better information technologists
- be exposed to new and innovative ways of approaching a variety of technical problems and issues
- analyze and evaluate organizational systems and processes to recommend software solutions to meet an organization's needs and goals
- develop the skills and knowledge required of an information technology professional
- be provided with a broad understanding of information technology, including hardware, software, communication, planning, analysis, design, implementation, and support
- explore and develop a deeper understanding in an area of IT
- specialization, or explore and document the professional experiences that have contributed to the current professional and technical skills possessed by the student

Students who successfully complete the BS-IT degree, will:

- possess a foundation of technical skills needed to begin a career in the area of information technology; or be able to apply the knowledge gained in the program to advance or secure a higher level position, if already in the field
- understand hardware, software, and organizational environments in which IT professionals work
- collect, organize, and modify information to reflect and address the organizational needs and workplace environment
- demonstrate familiarity with current information technologies and tools
- make critical decisions to provide solutions for

organizational requirements with respect to hardware, software, communication, planning, analysis, design, implementation, and support of various technologies in the IT industry

- employ research and critical thinking for analyzing and solving organizational problems using IT solutions
- enhance their design to pursue an advanced degree in the computer technology field
- analyze and compare the relative merits of IT systems with respect to a variety of criteria relevant to the task (i.e. efficiency, scalability, security)
- propose solutions and apply troubleshooting strategies to deal with various technical problems

In completing the requirements for the Bachelor of Science in Information Technology major, students will select either a major of 45 credits consisting of core coursework and an area of specialization; or a major of 30 credits of core coursework and the Experiential Learning Portfolio option. Six areas of undergraduate specialization are currently offered.

Information Systems Administration- This specialization is for students wishing to focus on the professional administrative coupled with the technical skills needed to develop highly skilled IT decision makers. In addition, students will be able to understand and apply the theories and strategies related to the areas of planning, organizing, and managing, and validating information systems.

Students who successfully complete the ISA specialization will:

- possess the ability to manage people and technology to address various facets of the professional and ethical uses of IS/IT
- possess the ability to integrate and synthesize the concepts of information systems.
- manage people and technology to address various facets of the professional and ethical uses of IS/IT.
- design and/or implement a system, component, or process to meet desired organizational needs.

Network and Systems Engineering- this specialization is for students to focus on how to effectively plan, implement, administer, and support various size networks in the enterprise. This specialization provides the groundwork for professionals to pursue highly recognized industry certification. Depending upon which elective(s) a student selects, opportunities exist to receive the necessary foundation to further prepare for certification programs such as CompTIA A+, CompTIA Network+, Microsoft MCSA/MCSE, Cisco CCNA, and CompTIA Linux+.

Students who successfully complete the NSE specialization will:

- know the principal features of Windows and the basics of enterprise networking
- be able to Install, upgrade and configure Windows
- understand the Active Directory Logical and Physical Structure of windows

- have the skills to plan and implement Active Directory structure that addresses the needs of an organization
- be able to configure network services such as DHCP, DNS, WINS, VPN, IPsec, IIS, and Proxy
- be able to manage the operation of a network from a central location, and be able to address issues such as network connectivity problems, interconnectivity among NetWare, Macintosh, and UNIX networks, and Internet connectivity
- be able to identify and resolve network problems by using troubleshooting tools and utilities.

Web Applications and Software Development - This specialization is for students choosing to focus on web programming skills and software development. Students will be able to evaluate business systems and processes and recommend software solutions, which meet organizational needs and goals; and develop the skills and knowledge required of an analyst-programmer for the research and development of web and computer-based applications.

Students who successfully complete the Software Development specialization will:

- Identify and develop a variety of software based on specific user needs, propose solutions, and apply troubleshooting strategies to deal with various workplace technical problems
- Use programming skills effectively to create products or systems and evaluate the impact of information technology in the workplace
- Possess a foundation of the underlying structures of web information systems and the characteristics of client/server processes
- Employ innovative techniques to implement information visualization, and the ability to enter, query, and retrieve data and information via Web

Telecommunications -This specialization is for students choosing to focus on building skills in an understanding of the rapidly expanding voice, data, graphics, and video network systems.

The overall objective of the Telecommunication specialization is to understand and analyze voice, data, graphics, video network systems. The Internet, intra/extranets, electrical signals, transmission, signaling, switching, global networks, and synchronous digital transmission systems; and to examine both the political and technical international issues associated with the flow of information.

Students who successfully complete the Telecommunications specialization will:

- Possess the ability to understand the professional and ethical responsibilities and international issues related to telecommunications
- Possess the ability to describe and utilize telecommunications systems to identify, formulate, and solve telecommunication related problems

BACHELOR OF SCIENCE (BS) IN INFORMATION TECHNOLOGY

DEGREE REQUIREMENTS

DISTRIBUTION REQUIREMENTS	45 credits
MAJOR PREREQUISITES	3 credits
MAJOR	30/45 credits
MAJOR CORE	30 credits
SPECIALIZATION OPTION	15 credits
PORTFOLIO OPTION	up to 30 credits
ELECTIVES	Variable

Minimum Total Degree Requirements.....**120 credits**

Recommended Distribution Course

Students considering graduate studies in IT are recommended to take MAT 152 Probability and Statistics.

Major Prerequisite Courses.....**3 credits**

CAT 102 Basic Computer Applications*

Major Core Courses.....**30 credits**

IT 190	Microcomputer Operating Systems*
IT 200	Foundations of Information Technology*
IT 310	Telecommunications and Computer Networks
IT 320	IT Security
IT 338	Web Design, Authoring and Publishing
CS 372	Software Engineering
CS 426	Databases
IT 400	IT Project Management
IT 499	Integrated Capstone Project
Approved 3-credit upper-level IT/CS/NSE Elective**	

**NSE specialization student MUST take NSE 305

Information Systems Administration

Specialization.....**15 credits**

IT 403	Customer Service Information Systems
IT 450	Administrative Information Systems
ADM 303	Administrative Theory and Practice
ADM 320	Finance and Budgeting
3 Credits of CS, IT or NSE upper-level electives	

Network and Systems Engineering

Specialization.....**15 credits**

NSE 210	Network Administration
NSE 310	Network Operating System I
NSE 320	Network Operating System II
NSE 405	Managing a Microsoft Network
Approved 3-credit upper level NSE elective	

Current List of Approved NSE electives:

NSE 330	Working with Cisco LAN Hardware
NSE 415	Network Operating System IV (Linux)
NSE 425	Advanced Directory Services
NSE 445	Advanced Network Services

Web Applications and Software Development

Specialization.....15 credits

- CS 301 Computer Programming
- CS 407 Database Programming and Administration
- CS 438 Web Programming and Administration
- CS 340 Java Programming for the Web
- 3-Credit CS, IT or NSE upper-level elective

Telecommunications Specialization.....15 credits

- IT 351 Voice & Digital Communications
- IT 460 Wireless and Mobile Computing
- IT 402 Advanced Topics in Signaling Systems
- IT 440 International Telecommunications
- 3-Credit CS, IT or NSE upper-level elective

Portfolio Option.....up to 30 credits

Students not choosing to complete a specialization may complete the Major Core and submit an Experiential Learning Portfolio in lieu of the specialization to satisfy degree requirements. In addition, all students may submit a Portfolio to help satisfy general elective requirements and/or up to 6 credits of upper-level CS/IT credits may be applied to the Major core elective, specialization elective, or count as general electives. Since the NSE core does not call for CS/IT electives, a 3 credit course substitution may be approved by the Academic Coordinator.

Credit By Examination

*Advanced students not transferring CAT 102, IT 190, or IT 200 or equivalent courses may test for credit by examination. Students should not sit for one of these examinations until they have reviewed their transfer credits with an advisor and are sure they are not duplicating transfer credit. Credit by examination may only be attempted once. If a student fails a credit by exam, they must register and complete the course. To maintain the integrity of the testing process, students may not review their examination results. A passing scores for credit by examination is 80% or higher.

Course Sequencing

The following charts will assist both student and advisors in the selection of BSIT courses and the sequence in which they are best taken. The chart has five levels. The first level lists appropriate classes for entering students. Whenever possible, it is **recommended** that students complete all first level classes before attempting second level classes. The third level classes **require** the completion of the first two levels. IT 499, capstone courses, should be completed after all other major classes. The one exception to this sequencing is the Network and System Engineering (NSE) Specialization. Students may complete IT 310 and the NSE specialization courses first if their goal is to achieve Microsoft MCSE certification first, and then complete the remainder of the BS-It degree requirements.

RECOMMENDED BS-IT COURSE SEQUENCING

Major Core Courses Sequencing

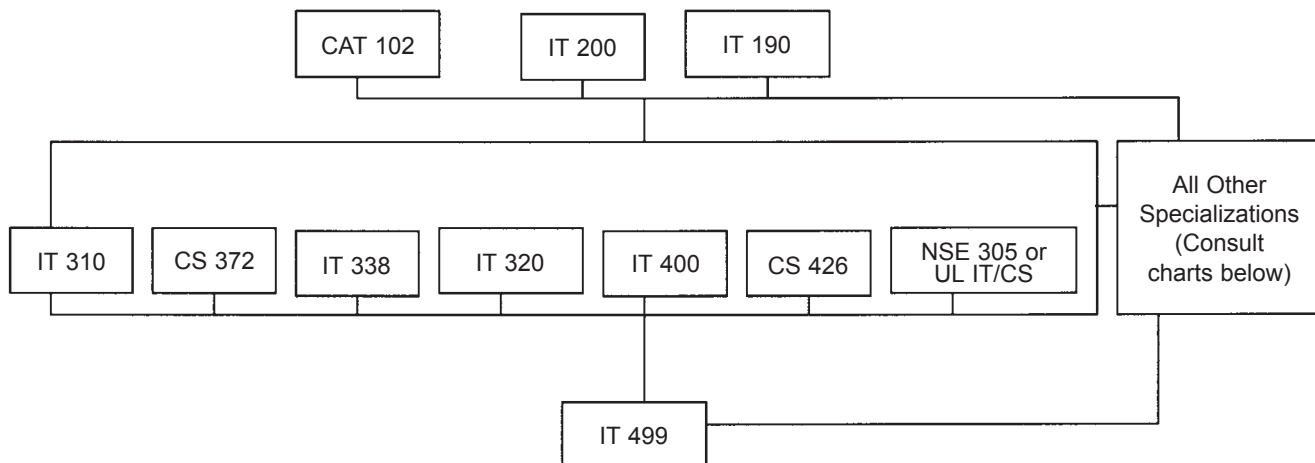

Information Systems Administration Specialization Sequencing

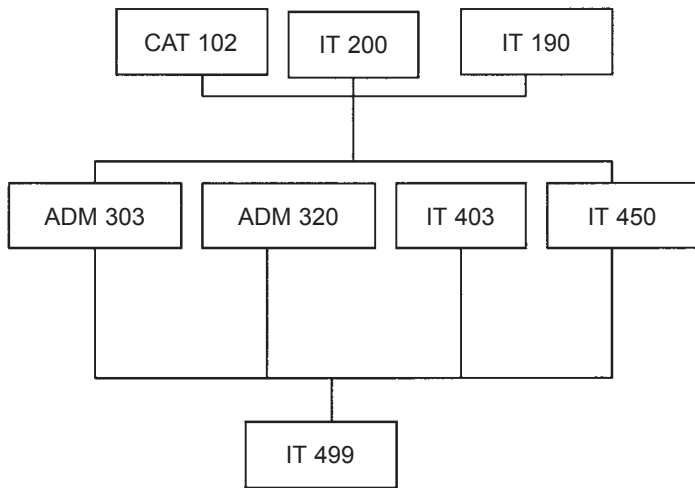

Telecommunications Specialization Sequencing

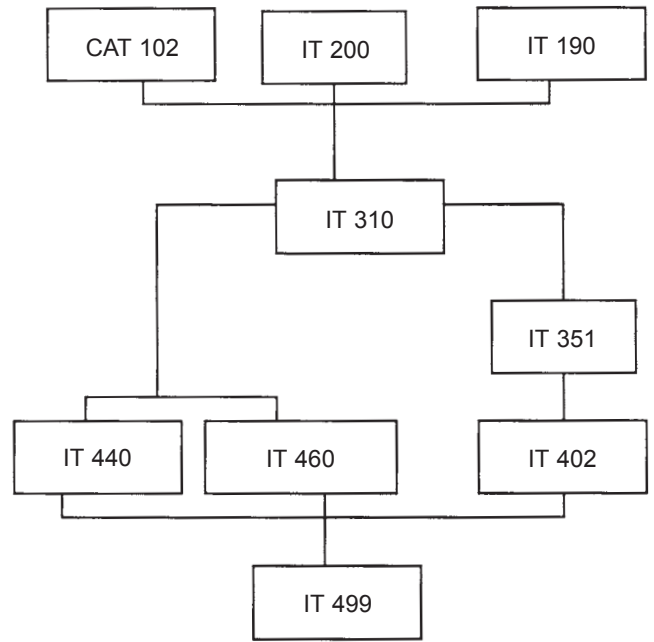

Web Applications and Software Development Specialization Sequencing

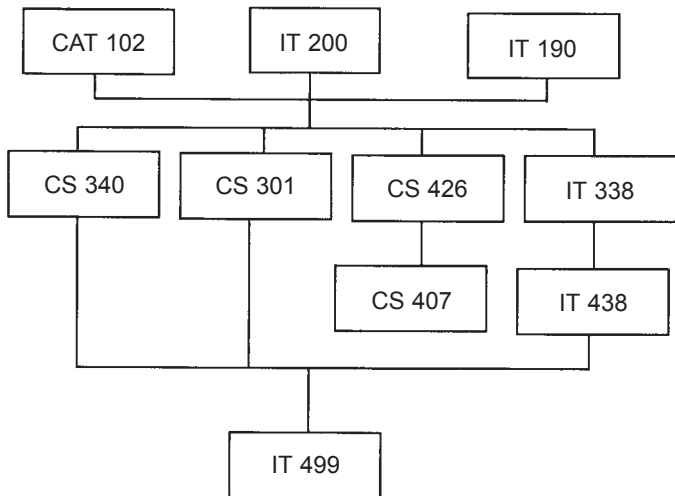

Network and Systems Engineering Specialization Sequencing

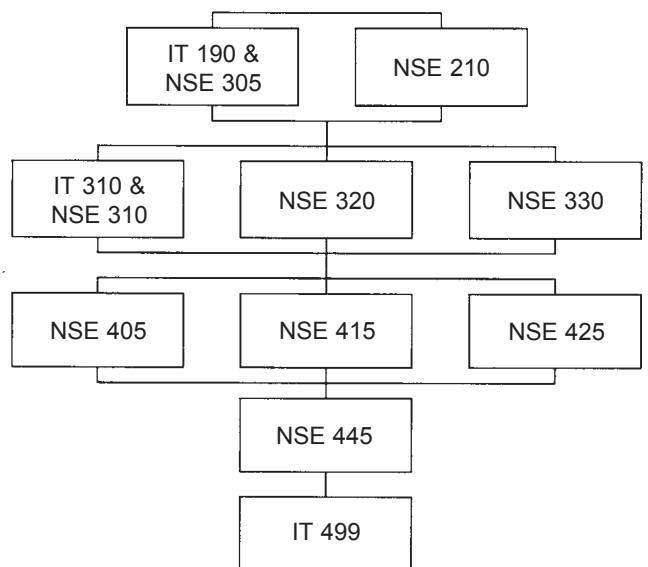

Major Electives

Students with a specialization that contains 3 or 6 credits of upper-level CS, IT, or NSE electives may fulfill these elective requirements with upper-level computer prefixed transfer courses, or upper-level Portfolio credits in computer science or information technology. The approved lists of CS/IT/ADM/NSE Course Electives are as follow: IT 450, IT 403, IT 402, IT 440, IT 451, IT 351, IT 402, IT 350, IT 420, CS 301, CS 407, CS 438, CS 340, CS 428, NSE 310, NSE 320, NSE 330, NSE 405, NSE 415, NSE 425, NSE 445, and ADM 353.

Transfer Credits in the Major

Majority of a student's major coursework must be taken at Barry University. Therefore a maximum of four equivalent courses (12 credits) will be accepted into the major core and a maximum of two equivalent courses (6 credits) will be accepted into the specialization area.

Authorized Microsoft IT Academy

This is a program with Microsoft that provides tools to facilitate the delivery of courseware that helps prepare students for Microsoft product certification.

As an IT Academy MCSE/MCSA (NSE) instructors are certified in the courses they teach, and we use Microsoft official or authorized curriculum in all Microsoft networking courses. Students and faculty also receive a discount on selected MCP exams when taken through an Authorized Academic Testing Center.

Authorized Academic Testing Center (AATC)

Barry University is a Virtual University Enterprises (VUE) testing center. VUE is the electronic testing division of NCS Pearson, servicing the Information Technology industry and the Professional Certification and Licensure markets. There are currently two testing centers at School of Adult and Continuing Education locations. One in Broward County at our Pembroke Pines location, and another in Brevard County at our Melbourne location.

To register for a certification exam call:
Pembroke Pines - (954) 392-0455
Melbourne - (321) 409-5553

MINOR AND POST-BACCALAUREATE CERTIFICATE IN INFORMATION TECHNOLOGY

The minor and certificate in Information Technology are current programs designed to provide adult students with the basic theoretical knowledge and technical skills required by today's information technology professionals.

Students will be presented with a solid foundation necessary for further study in the field of Information Technology. In doing so, students will: (objectives)

- become familiar with current technologies and tools while being exposed to new and innovative ways of approaching a variety of technical problems and issues
- learn to work in multi-vendor environments
- analyze and evaluate organizational systems and processes to recommend software solutions to meet an organization's needs and goals
- develop the basic skills and knowledge required of an information technology professional
- be provided with a basic understanding of information technology including hardware, software, communication, planning, analysis, design, implementation, and support

Students who successfully complete the minor or certificate in Information Technology will: (outcomes)

- possess a foundation of technical skills needed to begin a career in the area of information technology
- understand hardware, software, and organizational environments in which IT professionals work
- select, organize, and modify information to reflect and address the organizational needs and workplace environment
- propose solutions and apply troubleshooting strategies to deal with various technical problems
- support those making critical decisions that provide solutions for organizational requirements with respect to hardware, software, communication, planning, analysis, design, implementation, and support of various IT platforms
- employ research and critical thinking for analyzing and solving technical problems
- enhance their potential for admission to an advanced degree in the computer technology field

Minor in Information Technology

Students pursuing a bachelor of science degree other than the BS in Information Technology or those pursuing a Bachelor of Public Administration, may complete a minor in Information Technology.

The minor consists of the following seven courses and has a three-credit pre-requisite. A grade of C or higher is required in all minor coursework.

Pre-requisite Course.....3 credits
CAT 102 Basic Computer Applications

Minor.....21 credits
IT 190 Microcomputer Operating Systems
IT 200 Foundations of Information Technology
IT 310 Telecommunications and Computer Networks
IT 338 Web Design, Authoring and Publishing
CS 426 Databases
IT 400 IT Project Management
Approved 3-credit upper-level IT/CS/NSE Elective(

Post-Baccalaureate Certificate in Information Technology.....18 credits

IT 200 Foundations of Information Technology
IT 310 Telecommunications and Computer Networks
IT 338 Web Design, Authoring and Publishing
CS 426 Databases
IT 400 IT Project Management
Approved 3-credit upper-level IT/CS/NSE Elective(

Express Certificate in Information Technology.....24 credits

Any student with a High School diploma or its equivalent is eligible to enter this program.

IT 190 Microcomputer Basics
IT 200 Foundations of Information Technology
IT 310 Telecommunications and Computer Networks
IT 338 Web Design, Authoring and Publishing
CS 426 Databases
IT 400 IT Project Management
IT 450 Administrative Information Systems
Approved 3-credit upper-level IT/CS/NSE Elective(

NETWORK AND SYSTEMS ENGINEERING CERTIFICATES

The Network and Systems Engineering certificates focus on how to effectively plan, implement, administer, and support various size networks in the enterprise. These certificates provide the groundwork for professionals to pursue highly recognized industry certification. Depending upon which elective(s) a student selects, opportunities exist to receive the necessary foundation to further prepare for certification programs such as CompTIA A+, CompTIA Network+, Microsoft MCSA/MCSE, Cisco CCNA, and CompTIA Linux+.

Program Objectives:

- analyze business requirements for a network system architecture
- deploy, install, and configure network architecture components
- design network infrastructures
- evaluate and solve network systems problems

Program Outcomes: Students will -

- know the principal features of Windows and the basics of enterprise networking
- be able to Install, upgrade and configure Windows
- understand the Active Directory Logical and Physical Structure of windows
- have the skills to plan and implement Active Directory structure that addresses the needs of an organization
- be able to configure network services such as DHCP, DNS, WINS, VPN, IPsec, IIS, and Proxy
- be able to manage the operation of a network from a central location, and be able to address issues such as network connectivity problems, interconnectivity among NetWare, Macintosh, and UNIX networks, and Internet connectivity
- be able to identify and resolve network problems by using troubleshooting tools and utilities.

Post-Baccalaureate Certificate in Network and Systems Engineering.....18 credits

NSE 210 Network Administration
NSE 305 Advanced PC Hardware and Networking*
IT 310 Telecommunications and Computer Networks
NSE 310 Network Operating System I
NSE 320 Network Operating System II
NSE 405 Managing a Microsoft Network

*Has a pre-requisite of IT 190 Microcomputer Basics

Express Certificate in Network and Systems Engineering.....21 credits

IT 190 Microcomputer Basics
NSE 210 Network Administration
IT 310 Telecommunications and Computer Networks
NSE 305 Advanced PC Hardware and Networking
NSE 310 Network Operating System I
NSE 320 Network Operating System II
NSE 405 Managing a Microsoft Network

CERTIFICATES IN WEB APPLICATIONS AND SOFTWARE DEVELOPMENT

The certificates in Web Application and Software Development are for students wishing to focus on the design, development and support of web-based applications and computer software. Coursework will provide for web-design, web-programming, and software development, web-authoring and web site administration.

Pre-requisite Course 3 credits

CAT 102 Basic Computer Applications

Post-Baccalaureate Certificate in Web Applications and Software Development.....18 credits

CS 301 Computer Programming
CS 426 Databases
CS 407 Database Programming and Administration
CS 438 Web Programming and Administration
CS 340 Java Programming for the Web
IT 338 Web Design, authoring and Publishing

Express Certification in Web Applications and Software Development.....24 credits

Any student with a High School diploma or its equivalent is eligible to enter this program.

IT 190 Microcomputer Operating Systems
IT 200 Foundation of Information Systems
CS 301 Computer Programming
CS 426 Databases
CS 407 Database Programming and Administration
CS 438 Web Programming and Administration
CS 340 Java Programming for the Web
IT 338 Web Design, Authoring and Publishing

Certificate Requirements

Upon completion of the courses required for a certificate program, a student must meet with an advisor to complete the request to receive a certificate. The advisor will confirm successful completion of all courses required for a certificate, will obtain all necessary signatures, and will submit the paperwork.

A grade of C or higher is required in all certificate courses.

BACHELOR OF SCIENCE IN PROFESSIONAL ADMINISTRATION

The Bachelor of Science in Professional Administration degree is designed to provide student with the administrative and leadership competencies required by all organizations, whether private, public or non-profit, in order to be successful and achieve their goals. Course offerings are intended to address contemporary organizational theory and practice with an emphasis on application to the modern workplace

The program of study provides students with a broad knowledge of contemporary organizational principles and practices, while allowing for individualized emphasis in areas such as Information Technology, Human Resources, Health Services Administration, Public Administration, Legal Studies, or General Administration.

In addition to the technical content knowledge in the curriculum, the program objectives also emphasize workplace skill-building. Key learning outcomes include critical thinking, problem-solving, oral and written communication, teamwork and teambuilding, and leadership. Students will learn to view organizations from a systems perspective and as part of the international/global community.

The curriculum focuses on the challenging, complex and continually evolving environment of modern workplaces, and an emphasis is placed on the application of course concepts and principles.

The portfolio requirement enables a student to gain up to 30 credits for college level learning acquired through work experience and/or community service.

DISTRIBUTION REQUIREMENTS*.....45 CREDITS
Students considering graduate studies are recommended to complete MAT 152 Probability and Statistics. REQUIRED PORTFOLIO.....UP TO 30 CREDITS
CORE COURSES.....15 CREDITS
ELECTIVES.VARIABLE
CORE COURSES.....15 CREDITS
Students should plan their programs with advisor assistance so that courses can be completed in the sequence which follows.

ADM 303 Administrative Theory & Practice
ADM 320 Finance and Budgeting
ADM 353 Leadership Development
ADM 412 Quality and Productivity
ADM 464 Strategic Human Resource Administration

ADDITIONAL REQUIREMENTS.....15 CREDITS
Students must select courses from the following designated prefixes: (other courses with the approval of the academic coordinator.)
ADM (any ADM prefix course)
PLA (300, 339, 343, 440)
PUB (403, 406, 408)
HSA (any HSA prefix course)
IT (200, 310, 400)

(**Bold** type courses are prerequisites for students without previous experience.)

Note: Up to 6 credits of related courses may be accepted in transfer, or earned through discipline-specific portfolio credits to satisfy additional requirements. For information on Human Resources certificate, see Human Resources section under Bachelor of Professional Studies.

BACHELOR OF PROFESSIONAL STUDIES (BPS)

The Bachelor of Professional Studies degree program is designed for students who choose to pursue a professionally-oriented program of study. The degree is flexible in its design and thereby responds to diverse student needs and interests.

Students in this degree program are required to complete an area of specialization. Students may choose both to earn a specialization and to submit a portfolio.

To earn a specialization students select a specialization in one of the following: Exercise Science, Health Services Administration, Human Resources, Information Technology, Network and Systems Engineering, Professional Administration and Public Administration and Sports Management. Curriculum for each of these areas and University policies follow in this Bulletin.

Students who also want to earn credit for college-level learning acquired through professional work experience must submit a portfolio. The portfolio provides the mechanism for translating documented learning experience into Barry University credit. Students are expected to submit their portfolios before completing 90 credits.

Students must show college-level competence in one or more of the following categories in order to receive credit for professional work experience and/or community service: supervision, management, research, communications, interpersonal relations, creativity or critical thinking.

Students must attend a portfolio seminar during the first three semesters of enrollment. It is advisable to have portfolios submitted within one year of seminar attendance. If more than one year elapses from attendance at the first seminar, students must attend a second seminar.

Students must meet all of the following criteria at the time of portfolio submission:

1. Students have been fully accepted (see criteria for full acceptance in this bulletin/catalog).
2. Students must have completed English 329 with a grade of at least C or have demonstrated proficiency on the English exam.
3. Students must be in good academic standing (cumulative grade point average of 2.0 in all Barry University coursework).
4. Students are able to document at least five years of full-time professional work experience and/or community service.

If students do not meet the above criteria, the portfolio may not be submitted.

Student must submit their near-completed portfolios to their directors/advisors in sufficient time to allow for revisions. Completed portfolios must be submitted to the Miami campus in accordance with published deadline dates in the Semester schedules. Meeting these deadlines is the responsibility of the student. **The portfolio administrative fee is due at the time of submission.**

Normally the portfolio assessment will be completed by the portfolio evaluation committee eight to ten weeks after it is submitted. Upon evaluation, the student will be notified of the credits awarded.

Approximately one-third to one-half of the credits are upper-level.

The remainder are lower-level. Upper-level credits are determined by the amount of credits students receive in their portfolio evaluation at level two. Portfolio credits are general elective credits. Students may also receive credits for selected professional licenses. Please refer to the Assessment of Prior Learning Fact Book for eligible licenses.

DISTRIBUTION REQUIREMENTS.....45 credits
PORTFOLIO.OPTIONAL.....up to 30 credits
AREA OF SPECIALIZATION.....at least 21 credits
ELECTIVES.Variable

A maximum of 30 total credit hours in courses having School of Business prefixes (ACC, BUS, ECO, FIN, MGT, MIS and MKT) taken in residency at Barry and/or transferred in as equivalent courses from other institutions may count toward degree requirements.

AREAS OF SPECIALIZATION

University policies regarding an area of specialization are as follows:

1. Only elective courses may be applied toward an area of specialization.
2. An area of specialization consists of no fewer than 21 credit hours (but no more than 30 credit hours) of appropriate and approved course work.
3. 15 of the 21 credit hours must be taken through Barry University and bear Barry University course prefixes and numbers; 20 of 26 credit hours are required in the Exercise Science specialization.
4. 15 of the 21 credit hours must be in upper division courses, namely, 300 and 400 level courses; 20 of 26 credit hours are required in the Exercise Science specialization.
5. Bachelor of Professional Studies with a specialization in Professional Administration, Public Administration, Human Resources, Health Services Administration accepts up to 6 credits in portfolio and/or transfer credit into specialization electives only and accepts them in general electives.
6. Bachelor of Professional Studies with a specialization in Information Technology, Network and Systems Engineering, Exercise Science or Sport Management does not accept Portfolio credits in the specialization but will accept them in general electives.
7. Prerequisites must be honored.
8. The course title, prefix and number will be the determinant for course work in an area of specialization, e.g., ADM 412 Quality and Productivity.
9. Grades of C or higher must be earned in all course work in the area of specialization.

EXERCISE SCIENCE SPECIALIZATION

A specialization in Exercise Science is available to complement Bachelor of Professional Studies students who have an interest in medical, allied health, athletic training or other science-based fields and who wish to pursue further study in the areas of exercise prescription and fitness programming. Students must be able to document at least five years of full-time professional work experience or community service. The Exercise Science specialization is designed to prepare students for a wide variety of health-related careers which include, but are not limited to the following:

- Fitness and wellness programs: careers include health and fitness instructor, strength training instructor; exercise leader, health and fitness program director.
- Clinical programs such as cardiac/pulmonary rehabilitation: careers include exercise specialist, exercise test technologist, clinical program director.
- Other careers: a specialization in Exercise Science is a stepping stone for other health-related careers such as nursing, physical therapy and physician assistant.

A student may earn a specialization in Exercise Science by completing the following courses:

COURSE	CREDITS
SES 212 Emergency Response	3
SES 270 Concepts of Fitness and Wellness	3
SES 320 Kinesiology & Laboratory	4
SES 361 & 361L Exercise Physiology & Lab	4
SES 370 & 370L Fitness Assessment & Exercise Prescription & Lab	3
SES 441 & 441L Cardiac Rehabilitation & Lab	4
OR	
SES 461 & 461L Adv. Exercise Physiology & Lab	3
SES 463 Applied Physiology of Resistance Training	3
SES 486 Practicum in Exercise Science	2
SPECIALIZATION TOTAL:	26

HEALTH SERVICES ADMINISTRATION SPECIALIZATION AND POST-BACCALAUREATE CERTIFICATE

The Health Services Administration specialization and Post-Baccalaureate Certificate Programs are designed to provide a broad view of today's health care system and to prepare graduates for entry and middle management positions in such areas as hospitals, medical or dental clinics, group medical practices, managed care organizations, long-term care facilities, insurance companies, home health agencies, and government agencies. The curriculum emphasizes management skills for use in any health care setting.

The Health Services specialization is an excellent career pathway for persons licensed in clinical health and medical care professions but lacking an undergraduate degree. Additionally, the specialization prepares students for graduate studies in health care administration.

The objectives of the specialization in Health Services Administration are:

- to provide students with a comprehensive foundation in administrative theory and practice pertinent to the health care arena
- to meet the needs of adult students by developing the administrative knowledge, skills, and abilities that are associated with success in the health care organization's workplace
- to meet the needs of health service employers by preparing adult learners to meet the challenges of changing organizations
- to validate lifelong learning through experiential portfolio credit
- to provide a foundation for advance training and studies beyond the undergraduate level and to instill a desire for lifelong learning
- to deliver the program in a flexible, accelerated format while maintaining academic integrity

Students having health care experience should begin study with either **HSA 319 Health Care Finance**, **HSA 339 Health Law**, or **HSA 410 Management in Health Care**. This experience requirement consists of at least five years of experience, with at least one year in a supervisory or management capacity.

Otherwise, students should begin with **HSA 301 The Health Care System**, which is required prior to the five required courses in Health Care Administration. Students who wish to enroll in Health Services administration courses without the experience requirement or the HSA 301 prerequisite may take the 400 level coursework only with permission of the program director.

Health Services Administration Certificate

Students who are in other academic programs who wish to obtain a Health Services Administration Certificate must successfully complete a total of 18 credits from the Health Services Administration core requirements. Please notify your advisor of your intentions.

Post-Baccalaureate Health Services Administration Certificate Program

Students who have earned a baccalaureate degree from a regionally accredited school may enroll in the Post-Baccalaureate Certificate Program. The certificate will be awarded upon successful completion of **HSA 301** and the five required courses. For practicing professionals, **HSA 301** may be waived with permission of the program director.

CORE COURSES.....15 credits
Students should plan their programs with advisor assistance so that courses can be completed in the sequence which follows.

- HSA 319 Health Care Finance
- HSA 339 Health Law
- HSA 410 Management in Health Care
- HSA 475 Issues in Health Care
- HSA 499 Capstone in Health Service Administration

SPECIALIZATION ELECTIVES.....6 credits
These can be taken in any sequence or combination.

- HSA 301 The Health Care System
- HSA 425 Public and Community Health
- HSA 441 Health Care for the Elderly
- HSA 459 Independent Study in Health Care
- ADM Any ADM prefix course
- PSY 329 Understanding and Coping with Stress
- PSY 331 Counseling Techniques for Managers
- PSY 382 Development Psychology
- PSY 410 Group Dynamics and Decision-Making
- PSY 417 Psychology of Aging
- PSY 423 Industrial Psychology
- PUB 404 Concepts and Issues in Public Planning
- PUB 406 Human Resources in the Public Sector
- PUB 409 Contemporary Issues in Public Safety

Note: The total credits for students needing HSA 301 will be 24 credits.

HUMAN RESOURCES SPECIALIZATION

The Human Resources specialization is of special interest to students employed in the area of human resources development and administration. The program is designed to address the HR Competencies recommended by the Society for Human Resource Management (SHRM). The Human Resources specialization is earned by completing the approved twenty-one credits in the curriculum.

If graduates of the Human Resources specialization are subsequently admitted to the Master of Science in Human Resources Development and Administration degree program of the Barry University School of Education, their M.S. degree requirements will be reduced by three credit hours.

CORE COURSES.....9 credits
Students should plan their programs with advisor assistance so that courses can be completed in the sequence which follows.

- ADM 303 Administrative Theory and Practice
- ADM 312 Training and Development
- ADM 464 Strategic Human Resource Administration

ADDITIONAL ELECTIVES.....12 credits
Select four courses from the following:

- ADM 301 Labor Relations
- ADM 315 Diversity in the Workplace
- ADM 325 Compensation and Benefits
- ADM 330 Alternative Dispute Resolution
- ADM 361 Negotiation: Theory & Practice
- ADM 410 Recruitment and Selection
- ADM 412 Quality and Productivity

SPECIALIZATION ELECTIVE.....3 credits
Select an appropriate ADM or PSY course with advisor's approval.

HUMAN RESOURCES CERTIFICATE

Upon completion of the courses required for the specialization, a student can request a certificate from an advisor.



INFORMATION TECHNOLOGY SPECIALIZATION

The specialization in Information Technology is a current program designed to provide adult students with the basic theoretical knowledge and technical skills required by today's information technology professionals.

Students will be presented with a solid foundation necessary for further study in the field of Information Technology. In doing so, students will meet the following specialization objectives:

- become familiar with current technologies and tools while being exposed to new and innovative ways of approaching a variety of technical problems and issues
- learn to work in multi-platform/multi-vendor environments
- analyze and evaluate organizational systems and processes to recommend software solutions to meet an organization's needs and goals
- develop the basic skills and knowledge required of an information technology professional
- be provided with a basic understanding of information technology including hardware, software, communication, planning, analysis, design, implementation, and support

Students who successfully complete the BPS Specialization in Information Technology will: (outcomes)

- possess a foundation of technical skills needed to begin a career in the area of information Technology
- understand hardware, software, and organizational environments in which IT professionals work
- select, organize, and modify information to reflect and address the organizational needs and workplace environment
- propose solutions and apply troubleshooting strategies to deal with various technical problems
- support those making critical decisions that provide solutions for organizational requirements with respect to hardware, software, communication, planning, analysis, design, implementation, and support of various IT platforms
- employ research and critical thinking methodologies and concepts for analyzing and solving technical problems
- enhance their potential for admission to an advanced degree in the computer technology field

Required Distribution Course

To fulfill all or part of the Philosophy distribution requirement, those pursuing a BPS-IT specialization must complete PHI 305 Problems in Philosophy. This requirement will be waived for students who transfer two or more Philosophy coursework.

Recommended Distribution Course

Students considering the possibility of earning a Master's degree are recommended to take MAT 152 Elementary Probability and Statistics.

PREREQUISITE COURSES.....3 credits
CAT 102 Basic Computer Applications

INFORMATION TECHNOLOGY SPECIALIZATION
.....**21 credits**

IT 190 Microcomputer Operating Systems
IT 200 Foundations of Information Technology
IT 310 Telecommunications and Computer Networks
IT 338 Web Design, Authoring and Publishing
IT 400 IT Project Management
CS 426 Databases
IT 499 Integrated Capstone Project
A grade of C or higher is required in all specialization courses.



NETWORK AND SYSTEMS ENGINEERING SPECIALIZATION

The Network and Systems Engineering specialization focuses on how to effectively plan, implement, administer, and support various size networks in the enterprise. This specialization provides the groundwork for professionals to pursue highly recognized industry certification. Depending upon which elective(s) a student selects, opportunities exist to receive the necessary foundation to further prepare for certification programs such as CompTIA A+ , CompTIA Network+, Microsoft MCSA/MCSE, Cisco CCNA, and CompTIA Linux+.

Program Objectives:

- analyze business requirements for a network system architecture
- deploy, install, and configure network architecture components
- design network infrastructures
- evaluate and solve network systems problems

Program Outcomes: Students will -

- know the principal features of Windows and the basics of networking with windows
- be able to Install, upgrade and configure Windows
- understand the Active Directory Logical and Physical Structure of windows
- have the skills to plan and implement Active Directory structure that addresses the needs of an organization
- be able to configure network services such as DHCP, DNS, WINS, VPN, IPsec, IIS, and Proxy
- be able to manage the operation of a Windows network from a central location, and be able to address issues such as network connectivity problems, interconnectivity among NetWare, Macintosh, and UNIX networks, and Internet connectivity
- be able to identify and resolve network problems by using Windows troubleshooting tools and utilities

PREREQUISITE COURSE.....3 credits
IT 190 Microcomputer Operating Systems

NETWORK AND SYSTEMS ENGINEERING SPECIALIZATION.....21 credits

- NSE 305 Advanced PC Hardware and Networking
- IT 310 Telecommunications & Computer Networks
- NSE 310 Network Operating System I
- NSE 320 Network Operating System II
- NSE 405 Managing a Microsoft Network
- IT 499 Integrated Capstone Project
- Approved 3-credit upper level NSE elective

Current List of Approved NSE electives:

- NSE 330 Working with Cisco LAN Hardware
- NSE 415 Network Operating System IV (Linux)
- NSE 425 Advanced Directory Services
- NSE 445 Advanced Network Services

A grade of C or higher is required in all specialization courses.

Transfer Credits in the IT and NSE Specialization

The majority of a student's specialization coursework must be taken at Barry University. Therefore, a maximum of two equivalent courses (6 credits) will be accepted into the specialization.

Authorized Microsoft IT Academy

This is a program with Microsoft that provides tools to facilitate the delivery of courseware that helps prepare students for Microsoft product certification.

As an AATP program, our MCSE/MCSA (NSE) instructors are certified in the courses they teach, and Barry uses Microsoft official or authorized curriculum in all NSE prefix courses. Students and faculty also receive a discount on selected MCP exams when taken through an Authorized Academic Testing Center.

Authorized Academic Testing Center (AATC)

Barry University is a Virtual University Enterprises (VUE) testing center. VUE is the Electronic Testing division of NCS Pearson, servicing the Information Technology industry and the Professional Certification and Licensure markets. There are currently two testing center locations. One on the Main Campus in Miami Shores, and another in Broward County at the Pembroke Pines Location.

To register for a certification exam call:
Pembroke Pines - (954) 392-0455
Miami Shores - (305) 899-3891

Course Sequencing

Please refer to the section of this bulletin on the Bachelor of Science in Information Technology for course sequencing information.



PROFESSIONAL ADMINISTRATION SPECIALIZATION

The Professional Administration specialization is designed to provide students with the administrative and leadership competencies required by all organizations, whether private, public, or non-profit, in order to be successful and achieve their goals. Course offerings are intended to address contemporary organizational theory and practice with an emphasis on application to the modern workplace.

CORE COURSES.....15 credits
Students should plan their programs with advisor assistance so that courses can be completed in the sequence which follows.

ADM 303 Administrative Theory & Practice
ADM 320 Finance and Budgeting
ADM 353 Leadership Development
ADM 412 Quality and Productivity
ADM 464 Strategic Human Resource Administration

ADDITIONAL ELECTIVES.....6 credits
Students must select courses from the following designated prefixes:

ADM (any ADM prefix course)
PLA (300, 339,343, 440)
PUB (**301**, 403, 406, 408)
HSA (any HSA prefix course)
IT (200, 310, 400)

(**Bold** type courses are prerequisites for students without previous experience.)

PUBLIC ADMINISTRATION SPECIALIZATION AND POST-BACCALAUREATE CERTIFICATE PROGRAM

The Public Administration specialization is of special interest to the working professional in public and not-for-profit organizations or those who wish to pursue a career in public management. The coursework is designed to provide the student with an understanding and working application of the principles essential to the effective management of all public agencies.

Post-Baccalaureate Public Administration Certificate
The successful completion of five required courses listed below is required for a certificate to be awarded.

CORE COURSES.....15 credits
Students select a minimum of 5 core courses which must include

POS 303 Public Policy and Administration
PUB 402 Values and Ethics in Public Administration
PUB 403 Public Budgeting and Finance
PUB 404 Concepts and Issues in Public Planning
PUB 406 Human Resources in the Public Sector
PUB 407 Productivity Improvements in the Public Sector
PUB 409 Contemporary Issues in Public Safety
PUB 410 Methods and Techniques in Public Administration

SPECIALIZATION ELECTIVES.....6 credits
PUB 408 Public Management and the Political Process
ADM 301 Labor Relations
ADM 303 Administrative Theory and Practice
ADM 353 Leadership Development
ADM 361 Negotiation: Theory and Practice
ADM 412 Quality & Productivity
ADM 464 Strategic Human Resource Administration
POS 302 Comparative State and Local Government



SPORT MANAGEMENT SPECIALIZATION

The specialization in Sport Management is available to complement Bachelor of Professional Studies degree students with background and experience in sports or in other disciplines such as marketing, management, fitness, health, wellness, public relations, journalism, psychology and communications. It is designed to prepare students for opportunities in the sport-related fields including amateur, professional, and collegiate sport, as well as entrepreneurial businesses focusing on health, fitness, recreation, sport and sport products. Students must be able to document at least five years of full-time professional work experience or community service. A student may earn a specialization in Sport Management by completing the following required courses:

REQUIRED COURSES 15 CREDITS

SES 250	Sport & Recreation Management	3
SES 440	Sport Marketing, Promotions and Fundraising	3
SES 480	Contemporary Issues & Ethics in Sport	3
SES 485	Introduction to Law in Sport & Exercise Sciences	3
SES 486	Practicum in Sport Management	3

15

ELECTIVES 6 CREDITS

Recommended Courses:

SES 260	Leisure Planning and Programming	3
SES 380	Facility Design and Event Management	3
SES 431	Media Relations in Sport	3
SES 444	Financial Applications to Sport	3
SES 465	Administration of Programs and Facilities	3

SPECIALIZATION TOTAL: 21



BACHELOR OF LIBERAL STUDIES (BLS)

The Bachelor of Liberal Studies degree program is designed for students who choose to pursue a liberal arts program of study. The degree is flexible in its design and thereby responds to diverse student needs and interests.

Students in this degree program are required to complete a specialization. Students may choose both to earn a specialization and to submit a portfolio.

To earn a specialization students select a specialization in one of the following: Behavioral Sciences, Humanities, Legal Studies, Psychology/Human Services, and Social Welfare. Curriculum for each of these areas and University policies follow in this bulletin.

Students who also want to earn credit for college-level learning acquired through professional work experience must submit a portfolio. The portfolio provides the mechanism for translating documented learning experience into Barry University credit. Students are expected to submit their portfolios before completing 90 credits.

Students must attend a portfolio seminar during the first three semesters of enrollment. It is advisable to have portfolios submitted within one year of seminar attendance. If more than one year elapses from attendance at the first seminar, students must attend a second seminar.

Students must meet all of the following criteria at the time of portfolio submission:

1. Students have been fully accepted (see criteria for full acceptance in this bulletin/catalog).
2. Students must have completed English 329 with a grade of at least C or have demonstrated proficiency on the English exam.
3. Students must be in good academic standing (cumulative grade point average of 2.0 in all Barry University coursework).
4. Students are able to document at least five years of full time professional work experience and/or community service.

If students do not meet the above criteria, the portfolio may not be submitted. Students must submit their near-completed portfolios to their directors/advisors in sufficient time to allow for revisions. Completed portfolios must be submitted to the Miami campus in accordance with published deadline dates in the Semester schedules. Meeting these deadlines is the responsibility of the student.

The portfolio administrative fee must be paid when submitting the portfolio for evaluation.

Normally the portfolio will be assessed by the portfolio evaluation committee eight to ten weeks after it is submitted. Upon evaluation, the student will be notified of the credits awarded. Approximately one-third to one-half of the credits are upper-level. The remainder are lower-level. Upper-level credits are determined by the amount of credits students receive in their portfolio evaluation at level two. Portfolio credits are general elective credits. Students may also receive credits for selected professional licenses. Please refer to the Assessment of Prior Learning Fact Book for eligible licenses.

DISTRIBUTION REQUIREMENTS.....45 credits
PORTFOLIO.....up to 30 credits
AREA OF CONCENTRATION.....at least 24 credits
ELECTIVES:

VARIABLE (STUDENTS SELECT COURSES IN ANY APPROVED LIBERAL ARTS AREA.)

AREA OF SPECIALIZATION: 24-30 ELECTIVE CREDITS

Students who choose to earn an area of specialization will select elective courses in the following areas:

- Behavioral Sciences..... (24 credits)
- Humanities..... (30 credits)
- Legal Studies..... (24 credits)
- Psychology/Human Services..... (24 credits)
- Social Welfare..... (24 credits)

University policies regarding an area of specialization are as follows:

1. An area of specialization consists of no less than 24 credit hours but no more than 30 of appropriate and approved course work (24 credit hours for legal studies, 30 credits for humanities, 24 credits for psychology/human services, behavioral science, and social welfare).
2. 18 of the 24 credit hours must be taken through Barry University and bear Barry University course prefixes and numbers for the specialization in legal studies, behavioral sciences, psychology/human services and social welfare and 24 credit hours must be taken through Barry University and bear Barry University course prefixes and numbers for the specialization in humanities.
3. 18 of the 24 credit hours must be in upper division courses, namely, 300 and 400 level courses for the specialization in legal studies, behavioral sciences, psychology/human services and social welfare. 24 of 30 credit hours must be upper division courses for the humanities specialization.
4. Only one Special Topic course may be included in the specialization. The Special Topic course must be directly related by name and course content to the area of specialization.
5. The course title, prefix, and number will be the determinant for course work in an area of specialization.
6. Pre-requisites must be honored.
7. Up to six credits in portfolio and/or transfer may be accepted into the specialization electives
8. Grades of "C" or higher must be earned in all Specialization coursework



BEHAVIORAL SCIENCES SPECIALIZATION

The goal of the Bachelor of Liberal Studies program is to foster within adult learners the critical thinking, analytical skills, communication skills and interpersonal skills necessary for success across a wide range of professions and for productive and informed involvement within the community as empowered citizens. The Behavioral Sciences specialization focuses upon the analysis of human behavior, social organization, culture, social institutions from different academic traditions that collectively embrace a commitment to theory, basic and applied research, and social action and commentary. The curricular flexibility of the program affords opportunities for interdisciplinary exploration of human and societal problems and social realities and inequities from multiple disciplinary perspectives. The acquisition and conceptualization of knowledge from multiple perspectives is designed to facilitate critical thinking and integration which may result in more creative solutions for human and social ills. The program can be individually tailored to support further graduate training in counseling, marriage and family therapy, social work, education, law or organizational behavior.

The objectives of the BLS degree with a specialization in Behavioral Sciences are:

- to provide adult learners with a basic introduction to the methods of inquiry and research traditions of at least three different behavioral sciences disciplines
- to offer a critical analysis of human and societal assets and problems and the theoretical and philosophical assumptions that define and structure different behavioral science disciplines
- to offer an appreciation of the diversity of experience and differing opportunities afforded to social groups defined by gender, social class, race-ethnicity, age and collective identity
- to provide a basis for advanced training and education beyond the baccalaureate level and a desire for lifelong learning

- to help adults develop effective critical thinking and communication skills, and sensitivity to and knowledge of cultural, social, and ethical issues as they pertain to our understanding of human behavior, social organizations, social institutions, and social inequalities

Required Courses.....21 credits

PSY 281	Introduction to Psychology or	SOC 201	Introduction to Sociology
ANT 308	Perspectives in Anthropology or	SW 336	Social Welfare as a Social Institution
SOC 301	American Family or	SOC 307	Race and Ethnicity
SOC 415	Women in Contemporary Society or	SOC 417	Sociology of Death and Dying
PSY 325	Theories of Personality		
PSY 382	Developmental Psychology		
PSY 413	Abnormal Psychology or	PSY 428	Human Sexuality or
	PSY 410		Group Dynamics and Decision-Making

Specialization Elective.....3 credits

Any additional 3 credits at the 300 or 400 level in Anthropology, Criminology, Psychology, Social Welfare or Sociology

COURSE SEQUENCING FOR BEHAVIORAL SCIENCES SPECIALIZATION

The following chart will assist both students and advisors in the selection of courses and the sequence in which they are best taken. The chart has three levels. The first two levels of the chart are appropriate classes for entering students. It is recommended that students complete PSY 281 or SOC 201 before attempting 300-level classes. The 400 level classes at the third level of the chart require completion of the first two levels.

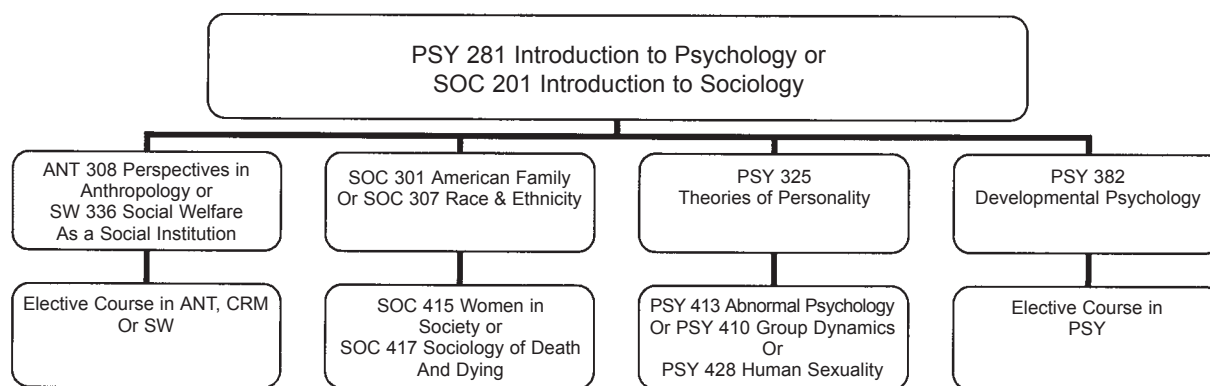

HUMANITIES SPECIALIZATION

The Humanities specialization is the interdisciplinary study of past and contemporary history of ideas and of the human experiences. This Study includes: philosophy, literature, and the fine arts (history of painting, sculpture, architecture, music). An historical perspective informs the sequence.

The Humanities specialization will establish a good background for those students who wish to enroll in the Master of Arts in Liberal Studies (MLS) programs. The Humanities program will enable students to achieve the following goals and objectives:

- To achieve an understanding of past major artistic, historical, and philosophical ideas
- To offer students an appreciation of past and current human history of human experience and achievements
- To provide the basis for advanced education beyond the baccalaureate level
- To enhance critical thinking and knowledge of ethical and cultural issues throughout history
- To develop self-initiative in exploring old and current ideas and issues
- To develop an awareness of the interrelationship among the various interdisciplinary areas and art forms
- To create a foundation for the understanding of the human condition

Students are required to complete three credits in HUM 303 and three in PHI 292. Additionally, students will earn at least three(3) credits in each of the areas below a total of 21 credits, and three credits in a capstone course. A total of thirty(30) credits must be completed.

Humanities 400 level course work electives may be applied towards the Master of Liberal Arts degree for partial credit.

HUMANITIES

HUM 303 Modern Currents in the Humanities (required)

PHILOSOPHY

PHI 292 Ethics (required)

LITERATURE

ENG 316 World Literary Masterpieces

ART HISTORY

ART 319 History of Western Art I **OR**

ART 320 History of Western Art II

MUSIC

MUS 327 History: Baroque and Classical **OR**

MUS 328 History: Romantic

HISTORY

HIS 101 Western Civilization I **OR**

HIS 102 Western Civilization II

THEATRE

TH 439 Theatre History I **OR**

TH 440 Theatre History II

Credits: 21

ELECTIVES

ART 400 Ancient Greek Art

ART 409 The Renaissance

ENG 315 The Novel

ENG 324 Major American Writers

ENG 337 Shakespeare and his Contemporaries

ENG 349 Women in Fiction

ENG 403 History of the English Language

HUM 305 Women in Antiquity

PHI 313 Philosophy of Art

PHI 316 Ancient Philosophy

PHI 317 Medieval Philosophy

PHI 318 Modern Philosophy

THE 303 Comparative Religious

THE 334 History of Christianity

Credits: 6

CAPSTONE SEMINAR

HUM 499

An interdisciplinary capstone course wherein students will complete a 10 to 15 research project that integrates the discipline-specific material in the elective courses within the contextual framework of the core courses. Directed by faculty member(s) in the appropriate discipline(s). Director's approval.

Credits: 3

TOTAL CREDITS: 30



LEGAL STUDIES SPECIALIZATION

The Legal Studies specialization is designed to provide a broad background in fundamental legal studies to students who desire to become paralegals or legal assistants working under the supervision of a lawyer. Legal assistants assume paralegal responsibilities as skilled members of a legal team in law firms, financial institutions, insurance companies, governmental agencies and related entities. The legal studies specialization consists of 24 credits of legal studies ("PLA" prefix) courses.

The objectives of the BLS degree with a specialization in Legal Studies are:

- to provide students with a comprehensive knowledge of legal systems in state and federal environments
- to meet the needs of adult learners by developing the legal research and writing skills that are essential to success in a legal environment
- to provide adult learners with the critical thinking and communication skills necessary to comprehend and function as a legal assistant within the civil and criminal practice areas of a modern law firm
- to encourage students to comprehend and fully utilize the connections between theory and practice
- to provide fundamental training and education that students will be able to utilize in the legal community as legal assistants/paralegals
- to deliver the program in a format that allows for flexibility in program planning and scheduling

Students with no experience in the legal community should begin study with **PLA 301 Law and the Legal System**. Bachelor of Liberal Studies degree-seeking students are awarded a Certificate of Participation upon application after completing the 24-credit core legal studies specialization requirement. Sixty Credit Hour Certificates of Completion are also awarded upon application to degree-seeking and undergraduate certificate program students. Legal Studies certificate students may convert to degree-seeking status any time during the course of their studies.

Students who are seeking a Bachelor of Science degree with a Legal Studies major or a Bachelor of Liberal Studies degree with a Legal Studies specialization must take the Certified Legal Assistant (CLA) examination, administered by the National Association of Legal Assistants, Inc., (NALA), prior to submitting an application for graduation. Proof of sitting for the CLA examination must be attached to the application for graduation. The CLA examination is offered at least twice each calendar year in Florida. Information on the CLA examination, eligibility and testing dates and sites can be obtained from NALA at <http://www.nala.org> or by writing to NALA, 1516 South Boston, Suite 200, Tulsa, Oklahoma 74119.

Legal Studies Undergraduate Certificate

The Undergraduate Certificate Program is a 60 credit hour program consisting of 8 substantive legal courses totaling 24 credit hours (described below) plus 30 credit hours of general distribution credits and six (6) credit hours of specified electives (with computer and wordprocessing skills being desired). A Certificate of Participation is awarded upon application after completing the 8 substantive legal courses. A 60 credit hour Certificate of Completion is awarded upon application after successful completion of the 60 credit hour curriculum. A grade of C or higher in each Legal Studies course is required to receive either a Certificate of Participation or a 60 credit hour Certificate of Completion.

The Undergraduate Certificate program is open to all Barry University students who choose to complete the applicable Legal Studies ("PLA") course and elective requirements; a student merely needs to submit an executed certificate application form after review by the student's Academic Advisor.

Post-Baccalaureate Legal Studies Certificate

The University also offers a Post-Baccalaureate Certificate program with admission limited to those students who possess an earned bachelor's degree (or higher) in any field prior to commencing Legal Studies at the University. The Post-Baccalaureate Certificate Program is a credit program that can generally be completed in one year (or less) and consists of 8 substantive legal courses totaling 24 credit hours. A grade of C or higher in each course is required to receive a Post-Baccalaureate Certificate of Completion

Recipients of either the 60 credit hours Undergraduate or Post-Baccalaureate Certificates of Completion, the Bachelor of Science degree with Legal Studies major or BLS degree with Legal Studies specialization are eligible to sit for the Certified Legal Assistant ("CLA") examination that is administered by the National Association of Legal Assistants, Inc. ("NALA").

REQUIRED COURSES.....15 credits
Students should plan their programs with advisor assistance so that courses can be completed in the sequence which follows.

- PLA 301 Law and the Legal System
- PLA 310 Legal Research
- PLA 315 Legal Writing
- PLA 320 Civil Litigation
- PLA 430 Criminal Law Practice

SPECIALIZATION ADDITIONAL REQUIREMENTS

.....9 credits

These may be taken in any combination or sequence.

- PLA 300 Special Topics
- PLA 330 Alternative Dispute Resolution
- PLA 339 Health Law
- PLA 343 Business Organizations
- PLA 350 Real Estate Law
- PLA 405 Administrative Law and Process
- PLA 440 Contracts
- PLA 452 Environmental Law
- PLA 460 Probate Proceedings
- PLA 470 Immigration Law
- PLA 480 Bankruptcy
- PLA 483 Family Law

PSYCHOLOGY SPECIALIZATION

The goal of the Bachelor of Liberal Studies program is to foster within adult learners the critical thinking, analytical skills, communication skills and interpersonal skills necessary for success across a wide range of professions and for productive and informed involvement within the community as empowered citizens. The Psychology specialization focuses specifically upon the theoretical, empirical and applied foundations of psychology. It is designed to support the success of those adults already employed as mental health paraprofessionals and/or prepare those adults who anticipate employment in these areas. Adults will emerge as more informed citizens cognizant of psychological ethics and able to recognize the complexities inherent in the description, prediction, analysis and influence of human behavior. The program has been designed to furnish necessary prerequisites for graduate education in psychology or to support graduate training in related fields such as social work, law, counseling, education or organizational behavior.

The objectives of the BLS degree with a specialization in Psychology are:

- to provide adult learners with an introduction to the theoretical, empirical, and applied foundations of psychology
- to define and demonstrate appropriate applications of the scientific method to the study of human behavior
- to foster the development of effective critical thinking and communication skills, and sensitivity to and knowledge of cultural, developmental and ethical issues as they pertain to our understanding of human behavior and clinical interventions
- to empower adult learners with the skills necessary to succeed as mental health related paraprofessionals
- to provide a foundation for advanced training and education beyond the baccalaureate level and to install a desire for lifelong learning

REQUIRED COURSES.....18 credits

- PSY 281 Introduction to Psychology*
- PSY 325 Theories of Personality*
- PSY 382 Developmental Psychology*
- PSY 410 Group Dynamics and Decision-Making **or** PSY 428 Human Sexuality
- PSY 413 Abnormal Psychology*
- PSY 452 Child & Adolescent Psychopathology*

SPECIALIZATION ELECTIVES.....6 credits

- PSY 301 Psychology of Drug and Alcohol Abuse
- PSY 306 Psychology of Women
- PSY 320 Tests and Measurements* (MAT 152 prerequisite)
- PSY 329 Understanding and Coping with Stress
- PSY 333 Experimental Psychology* (MAT 152 prerequisite)
- PSY 370 Social Psychology
- PSY 410 Group Dynamics and Decision-Making
- PSY 417 Psychology of Aging
- PSY 423 Industrial Psychology
- PSY 428 Human Sexuality
- PSY 449 Adolescent Psychology
- PSY 490 Physiological Psychology

*Strongly recommended for students anticipating graduate studies in Psychology.

COURSE SEQUENCING FOR PSYCHOLOGY SPECIALIZATION

The following chart will assist both students and advisors in the selection of courses and the sequence in which they are best taken. The chart has three levels. Students planning on attending graduate school in a mental-health related profession are strongly encouraged to complete MAT 152 during their first or second semester of enrollment. This should be followed by enrollment in PSY 320. The first two levels of the chart are appropriate classes for entering students. It is recommended that students complete PSY 281 before attempting 300-level Psychology classes. The 400 level classes require successful completion of the 300 level classes

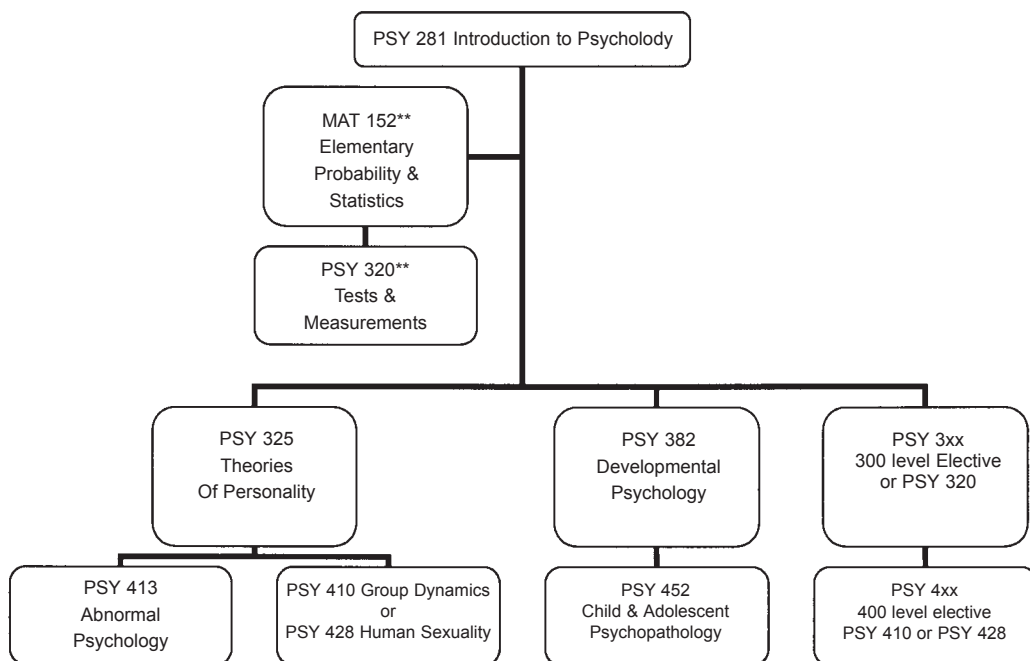

SOCIAL WELFARE SPECIALIZATION

The Social Welfare specialization consists of three social work courses, a human biology course, two additional required classes and one specialization elective from an array of social and behavioral sciences offerings. It is designed to serve two functions. It orients students to human functioning and dynamics to help ready them for bachelor's level employment in social and human service settings. In addition, it paves the way to graduate study in Barry University's School of Social Work.

Information on the graduate program in social work may be obtained from the School of Social Work.

REQUIRED COURSES.....21 credits

- SW 336 Social Welfare as a Social Institution
- SW 401 Social Welfare Policy and Services I
- SW 470 Human Behavior and Social Environment
- BIO 302 Human Biology
- PSY 325 Theories of Personality
- PSY 413 Abnormal Psychology
- SOC 301 American Family or SOC 307 Race and Ethnicity

SPECIALIZATION ELECTIVES.....3 credits

Any Barry course with PSY, SOC prefixes courses (except SOC 309, 310), approved transfer class, or through discipline-specific portfolio credits.

COURSE SEQUENCING FOR SOCIAL WELFARE SPECIALIZATION

The following chart will assist both students and advisors in the selection of courses and the sequence in which they are best taken. The chart has three levels. The first two levels of the chart are appropriate classes for entering students. It is recommended that students complete PSY 281 or SOC 201 before attempting 300-level classes. The 400 level classes at the third level of the chart **require** completion of the first two levels.

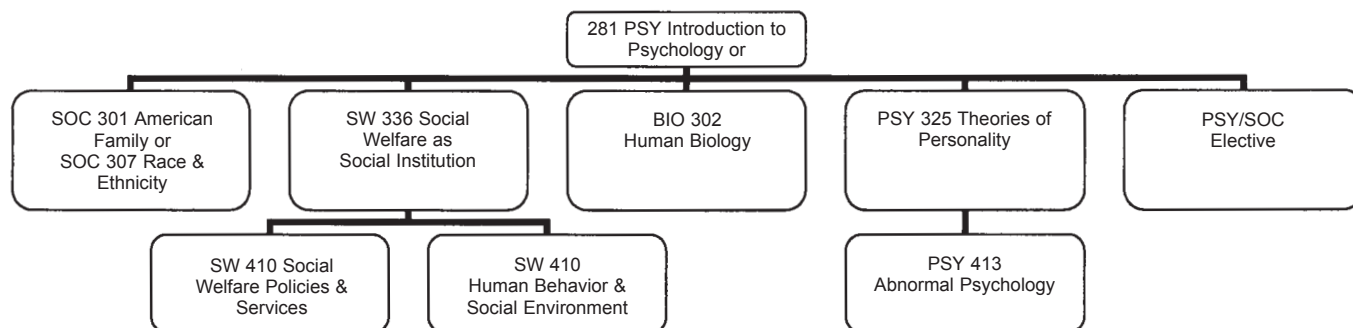

TEACHER CERTIFICATION IN ENGLISH

The School of Adult and Continuing Education and the Adrian Dominican School of Education(ADSOE) jointly sponsor an alternative teacher certification in English for secondary and middle schools in the State of Florida. Candidates must have a bachelor's degree. In addition, they need eighteen(18) semester hours in English for middle school and thirty(30)hours for secondary school. These courses must include three(3) credits in English grammar and composition above the 200 level, 3(three) credits in Speech, 12(twelve)credits in English literature for middle schools and twenty-four(24) credits in English literature for secondary. Candidates are strongly advised to take a teaching methods class such as EDU 414 (Classroom Management) and a developmental psychology class such as PSY 382. Upon completing the bachelor's degree and the English courses, prospective teachers must apply to the State of Florida for a "statement of eligibility"; middle and secondary schools can hire teachers who possess this document. After obtaining employment, teachers are issued a temporary teaching certificate. Within three years they must pass three state examinations (the General Knowledge Test, the FTCE Professional Test and the FTCE Subject Matter Test) and take the remaining education courses. For further information contact Dr. Cynthia Davis (305 591-7240) or Dr. Patricia Feito (305-899-3348).